

OM1125

LoRaWAN Gateway Module Datasheet

V1.0.0

Document Information

Version	Time	Description	Remark
V1.0.0	2018-7-12	Preliminary version	Mike

Table of Contents

1. Description	1
1.1 Overview.....	1
1.2 Product features.....	1
1.3 Function block diagram	2
2. Pin definition	3
2.1 Pin assignment	3
2.2 Pin description.....	3
3. Specifications	5
3.1 General specifications	5
3.2 Electric specifications	5
3.3 Absolute maximum rating	6
3.4 Operating conditions	6
4. Typical hardware connections	8
4.1 Physical dimensions.....	8
4.2 Reference Circuit	8
4.3 Interfaces.....	9
4.3.1 Interface to host MCU	9
4.3.2 Power pins	9
4.3.3 RF connection	9
4.3.4 RESET pin	9
4.3.5 GPS_PPS.....	9
4.3.6 RF enable	9
5. Reliability test and approves	10
6. Package	10

1. Description

1.1 Overview

OM1125 is a LoRa Gateway Module with industrial standard mini PCI express form factor based on SX1301 chipset and 2*SX1255 RF end-front. This mPCIe module can be used in any embedded platform offering a free mPCIe slot with USB/SPI connectivity and capable of providing enough power for the module, enables low-power wide area communication capabilities to your new gateway design or existing industrial routers/computer.

Each module support eight(8) programmable Lora parallel demodulation channels, allowing it to receive up to eight LoRa® modulated packets simultaneously. -142.5dBm high sensitivity combine with +27dBm power amplifier yields industry leading link budget making it optimal for applications requiring extended range and robustness.

Typical applications

- ✓ Automated Meter Reading
- ✓ Home and Building Automation
- ✓ Wireless Alarm and Security Systems
- ✓ Industrial Monitoring and Control
- ✓ Machine to Machine (M2M)
- ✓ Internet of Things (IoT)

OM1125 LoRa gateway modules are available in four product variants

NO.	Model	Description	Remark
1	OM1125-W	433MH, Suitable for China &Europe	
2	OM1125-C	470~510MHz, Suitable for China	

Table1.1 Product variants

1.2 Product features

- ✓ **Multichannel:** Eight (8) programmable Lora parallel demodulation channels.
- ✓ **SPI Interface:** The SPI interface gives access to the configuration register of SX1301 via a synchronous full-duplex protocol.
- ✓ **USB2.0 Interface:** Build in FT232H chip convert SPI interface of SX1301 to USB2.0 .
- ✓ Compact mini PCI express form factor TYP. 50.8*30.3*4.7mm (W*L*H)
- ✓ Standard mini PCI express supply voltage +3.3V
- ✓ Firmware upgradeable
- ✓ Environmentally friendly RoHS compliant

1.3 Function block diagram

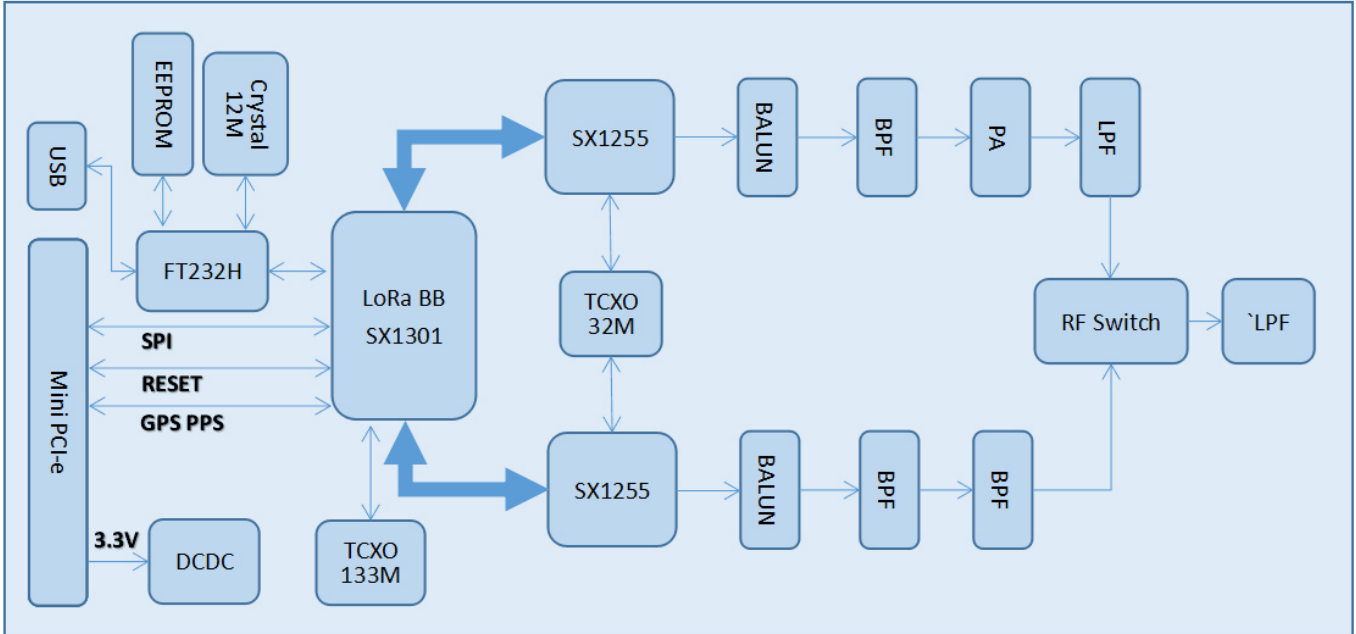

2. Pin Definition

2.1 Pin assignment

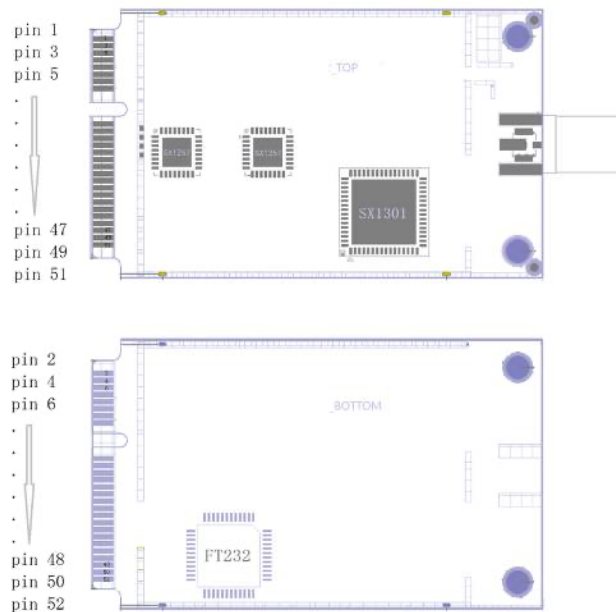

2.2 Pin description

No.	Symbol	Type	Description
1	NC	N/A	Not connected (Default)
2	+3.3V	Supply input	Supply voltage to the engine board.
3	NC	N/A	Not connected (Default)
4	GND	GND	Ground
5	NC	N/A	Not connected (Default)
6	NC	N/A	Not connected (Default)
7	NC	N/A	Not connected (Default)
8	NC	N/A	Not connected (Default)
9	GND	GND	Ground
10	NC	N/A	Not connected (Default)
11	NC	N/A	Not connected (Default)
12	NC	N/A	Not connected (Default)
13	NC	N/A	Not connected (Default)
14	NC	N/A	Not connected (Default)
15	GND	GND	Ground
16	NC	N/A	Not connected (Default)
17	NC	N/A	Not connected (Default)
18	GND	GND	Ground

19	NC	N/A	Not connected (Default)
20	NC	N/A	Not connected (Default)
21	GND	GND	Ground
22	/Reset	Reset input	Reset Module, Active-low device Reset input
23	NC	N/A	Not connected (Default)
24	+3.3V	Suupply input	Main power supply to the engine board.
25	NC	N/A	Not connected (Default)
26	GND	GND	Ground
27	GND	GND	Ground
28	NC	N/A	Not connected (Default)
29	GND	GND	Ground
30	NC	N/A	Not connected (Default)
31	NC	N/A	Not connected (Default)
32	NC	N/A	Not connected (Default)
33	NC	N/A	Not connected (Default)
34	GND	GND	Ground
35	GND	GND	Ground
36	USB_DM	USB Data Line D-	USB Data Signal Minus
37	GND	GND	Ground
38	USB_DP	USB Data Line D+	USB Data Signal Plus
39	+3.3V	Supply inout	Main power supply to the engine board.
40	GND	GND	Ground
41	+3.3V	Supply inout	Main power supply to the engine board.
42	NC	N/A	Not connected (Default)
43	GND	GND	Ground
44	NC	N/A	Not connected (Default)
45	SCK	Host SPI interface	SPI interface
46	GPS_IN	GPS_IN	GPS pps in
47	MISO	Host SPI interface	SPI interface
48	NC	N/A	Not connected
49	MOSI	Host SPI interface	SPI interface
50	GND	N/A	Ground
51	CSN	Host SPI interface	SPI interface
52	+3.3V	Supply inout	Main power supply to the engine board.

Table 2.1 Pin definition

3. Specifications

3.1 General specifications

Parameters	Description
Modulation type	ISM Band LoRa [®]
LoRa chipset	SX1301
Multi-channel	Eight (8) uplink , one (1) down link
Package	Mini PCI express
Host interface	USB/SPI
Frequency	433MHZ, 470~510MHZ(Opt.)
Receiving sensitivity	-142.5dBm
Tx power	+27dBm typ30dBm (Opt.)
Communication range	3~5KM in urban area, >15KM line-of-sight
Supply voltage	+3.3V
Power consumption	Tx(Max)<700mA Rx <200mA
Operating temperature	-40~+85°C (industrial grade)
Operating humidity	10%~90%, no-condensing
Dimensions	TYP. 50.8*30.3*4.7mm (W*L*H)
ESD (Human Body Model)	JEDEC JS-001 Standard ±1kV, Class 2

Table3.1 General specification

3.2 Electric specifications

ESD Notice: OM1125 is a high-performance radio frequency device. It satisfies:

- ✓ Class 2 of the JEDEC standard JESD22-A114 (Human Body Model) on all pins.
- ✓ Class III of the JEDEC standard JESD22-C101 (Charged Device Model) on all pins

It should thus be handled with all the necessary ESD precautions to avoid any permanent damage.



The limiting values given are in accordance with the Absolute Maximum Rating System. Stress above one or more of the limiting values may cause permanent damage to the device. These are stress ratings only, and operation of the device at these or at any other conditions above those given in the Characteristics sections of the specification is not implied. Exposure to these limits for extended periods may affect device reliability.

3.3 Absolute maximum rating

Symbol	Description	Condition	Min	Max.	Unit
3.3Vaux	Module supply voltage	Input DC voltage at 3.3Vaux pins	-0.3	3.6	V
USB	USB D+/D- pins	Input DC voltage at USB interface pins		3.6	V
SPDT_SEL	Port select	Input DC voltage at SPDT_SEL input pins	-0.3	3.6	V
RESET	MPCI reset input	Input DC voltage at RESET input pin	-0.3	3.6	V
SPI	SPI interface	Input DC voltage at SPI interface pin	-0.3	3.6	V
GPS_PPS	GPS 1 pps input	Input DC voltage at GPS_PPS input pin	-0.3	3.6	V
Rho_ANT	Antenna ruggedness	Output RF load mismatch ruggedness at ANT1		10:1	VSWR
Tstg	Storage Temperature		-40	85	°C

Table3.2 absolute maximum rating



Stressing the device beyond the “Absolute Maximum Ratings” may cause permanent damage. The product is not protected against over-voltage or reversed voltages. If necessary, voltage spikes exceeding the power supply voltage specification, given in table above, must be limited to values within the specified boundaries by using appropriate protection diodes.

3.4 Operating conditions



All specifications are at an ambient temperature of 25° C. Extreme operating temperatures can significantly impact specification values. Applications operating near the temperature limits should be tested to ensure the specification.

Parameter	Min.	Typ	Max.	Unit	Remarks
Normal operating temperature	-20	+25	+65	°C	fully functional and meet 3GPP specifications
Extended operating temperature	-40		+85	°C	RF performance may be affected by outside normal operating range
Storage Temperature	-40		+125	°C	

Table3.3 operating temperature range



Operating beyond the specified operating conditions can affect device reliability.

Symbol	Parameter	Min.	Typical	Max.	Unit
3.3Vaux	operating supply voltage	3.00	3.30	3.60	V

Table3.4 Operating power supply range



Operating beyond the specified operating conditions can affect device reliability.

Item	Parameter	SPEC			Unit	Condition
		MIN	TYP	MAX		
TX	Transmit Frequency	433		433	MHz	ISM Band(OM1125-W)
	Transmit Frequency	470		510	MHz	ISM Band(OM1125-C)
	Transmit Power		+27	+30	dBm	Including ANT Gain
	Frequency Deviation		12.5		KHz	25 °C
RX	Receiving Sensitivity		-142.5		dBm	

Table3.5 RF receiver characteristics



OM1125 series LoRa RF characteristics are specified in the SX1255series Data Sheet .

Mode	Condition	Min	Typ	Max	Unit
RF Idle	All of the chip on the board enter idle mode or shutdown.		70		uA
Rx active	TX disabled and shutdown PA.		120	185	mA
Tx active	The power of TX channel is 27dBm and 3.3V supply.		520	700	mA

Table3.6 Current consumption

4. Typical Hardware Connections

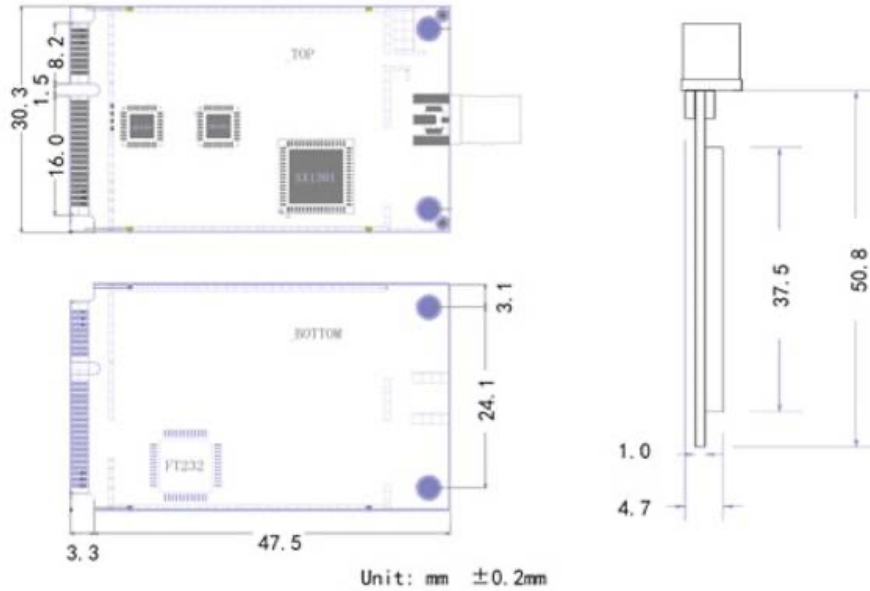
4.1 Physical dimensions



Item	Length	Width	Thickness	Unit	Remark
Dimensions	50.8	30.3	4.7	mm	

Table4.1 dimensions

4.2 Reference Circuit

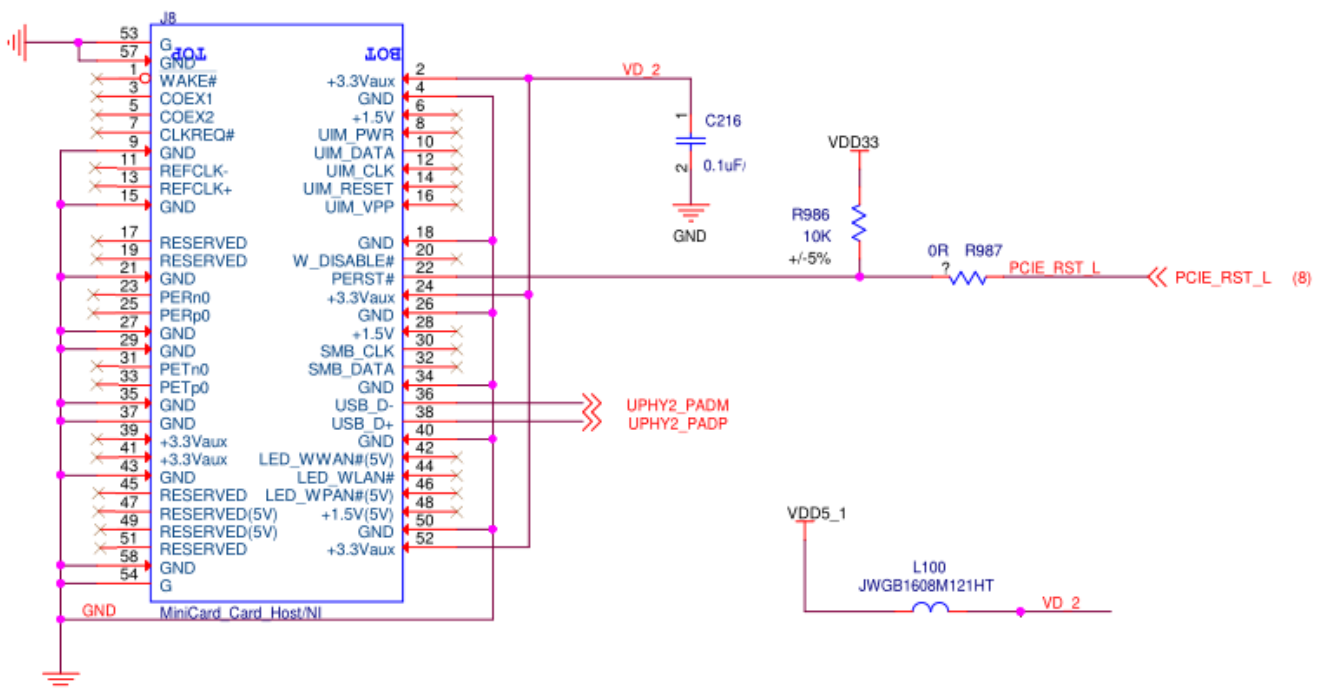

4.3 Interfaces

Reference circuit design shows the typical hardware connections for the module. Interfacing to the module requires connecting to the signals provided on the OM1125 mPCIe connector as listed in pin description. Specific interface connections are discussed in this chapter.

4.3.1 Interface to host MCU

✓ SPI interface

A SPI interface is provided on the PCIe_SCK, PCIe_MISO, PCIe_MOSI, PCIe_CSN pins of the system connector. The SPI interface gives access to the configuration register of SX1301 via a synchronous full-duplex protocol. Only the slave side is implemented.

✓ USB interface

OM1125 series modules support high speed USB interface with a built in TF232H chip convert SPI to USB, can be connected to any USB host equipment with compatible drivers. The module can use the USB signals through the mPCIe interface.

4.3.2 Power pins

OM1125 series modules has multiple power and ground pins available on the mPCIe connector. It is recommended that all power and ground pins be used when connecting to the module.

4.3.3 RF connection

OM1125 series modules have a U.FL connector for interfacing with an external antenna. For proper operation, antenna selection must consider frequency band and impedance.

4.3.4 RESET pin

OM1125 series modules have an active-low reset input. Pulling this signal low during normal operation will cause the module to execute a reset cycle.

4.3.5 GPS_PPS

OM1125 series modules include a GPS_PPS input used to receive time-stamped packets.

4.3.6 RF enable

OM1125 series modules have an input signal used to enable the RF radio on the module. A low level on the RF_ENABLE pin will disable all RF transmission and reception.

5. Reliability Test and Approves

Tests for product family qualifications are according to ISO 16750 "Road vehicles – Environmental conditions and testing for electrical and electronic equipment", and appropriate standards.



Products marked with this lead-free symbol on the product label comply with the "Directive 2002/95/EC and Directive 2011/65/EU of the European Parliament and the Council on the Restriction of Use of certain Hazardous Substances in Electrical and Electronic Equipment" (RoHS). All Origo OM1125 modules are RoHS compliant.

6. Package

Module	Package			Article number
	Form	QTY	Size	
OM1125	Trays	As required	As required	Undetermined

Table6.1 package